

EM powerLED SELFTEST 1 – 2 W

Combined emergency lighting LED Driver 1 – 4 W

Product description

- Emergency lighting LED Driver with self-test function
- For self-contained emergency lighting
- SELV for output voltage < 60 V DC
- Low profile casing (21 x 30 mm cross-section)
- 5-year guarantee

Properties

- Mains and emergency operation
- Self-test as per IEC 62034
- Constant current mode
- With either screw or clip fastening (clip-fix)
- 1, 2 or 3 h rated duration
- Selectable operating time (jumper)
- Output power limitation
- Two-colour status display LED
- „Rest mode“ function
- Simple set-up
- Automatic restart after LED replacement
- Electronic multi-level charge system
- Pulse current charging to optimize battery life
- SELV (outputs powerLED, battery, status LED, test switch)
- Polarity reversal protection for battery
- Deep discharge protection
- Very low energy consumption from the battery after activation of the deep discharge protection
- Short-circuit-proof battery connection
- Emergency lighting LEDs available
- Self-test:
 - Status of the battery
 - Status of the LED
 - Charge condition
 - Function test
 - Life-time test

Batteries

- High-temperature cells: 2 Ah
- NiMH batteries
- Cs cells
- 4-year design life
- 1-year guarantee
- For battery compatibility refer to table „Battery selection“



Screw-fix

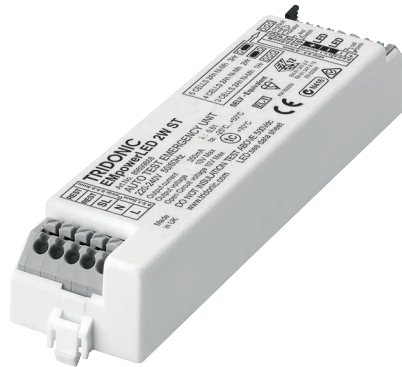

Clip-fix



Standards, page 5

For wiring diagrams and installation examples, page 8

EM powerLED SELFTEST 1 – 2 W

Combined emergency lighting LED Driver 1 – 4 W

Technical data

Rated supply voltage	220 – 240 V
Mains frequency	50 / 60 Hz
Forward voltage range LED module (1 x LED)	2.8 – 3.4 V
Forward voltage range LED module (2 x LED)	5.6 – 6.8 V
Max. open circuit voltage	10 V
Time to light	0.31 s from detection of emergency event
Overvoltage protection	320 V (for 1 h)
Battery discharge current	See page 4
Max. casing temperature t_c	70 °C
Ambient temperature t_a	-25 ... +50 °C
Mains voltage changeover threshold	according to EN 60598-2-22
Type of protection	IP20

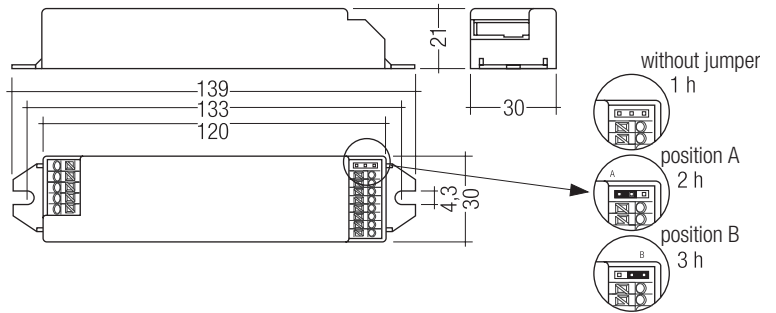

Screw-fix

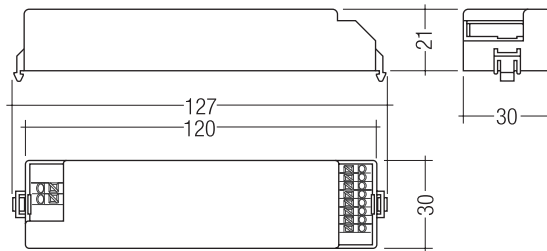

Clip-fix

Ordering data

Type [®]	Article number	Dimensions L x W x H	Packaging, carton	Packaging, pallet	Weight per pc.	Max. number of LED	Power
Screw fastening version							
EM powerLED 1 W ST	89899860	139 x 30 x 21 mm	25 pc(s).	1,200 pc(s).	0.056 kg	1	1.2 W
EM powerLED 2 W ST	89899861	139 x 30 x 21 mm	25 pc(s).	1,200 pc(s).	0.056 kg	2	2.0 W
Clip fastening version							
EM powerLED 1 W ST	89899867	127 x 30 x 21 mm	25 pc(s).	1,200 pc(s).	0.056 kg	1	1.2 W
EM powerLED 2 W ST	89899868	127 x 30 x 21 mm	25 pc(s).	1,200 pc(s).	0.056 kg	2	2.0 W

Specific technical data

Type [®]	Rated duration	Typ. λ (at 230 V, 50 Hz) ^①	Non-maintained operation: Mains current			Non-maintained operation: Mains power			Maintained operation: Mains current			Maintained operation: Mains power		
			Initial charge	Fast recharge	Trickle charge	Initial charge	Fast recharge	Trickle charge	Initial charge	Fast recharge	Trickle charge	Initial charge	Fast recharge	Trickle charge
EM powerLED 1 W PRO EZ-3	1 h	0.52c	14 mA	16 mA	13 mA	1.1 W	1.4 W	1.0 W	28 mA	30 mA	25 mA	3.2 W	3.6 W	2.8 W
EM powerLED 1 W PRO EZ-3	2 h	0.52c	14 mA	16 mA	13 mA	1.1 W	1.4 W	1.0 W	28 mA	30 mA	25 mA	3.2 W	3.6 W	2.8 W
EM powerLED 1 W PRO EZ-3	3 h	0.52c	15 mA	18 mA	13 mA	1.1 W	1.6 W	1.0 W	28 mA	30 mA	25 mA	3.2 W	3.6 W	2.8 W
EM powerLED 2 W PRO EZ-3	1 h	0.55c	15 mA	18 mA	13 mA	1.2 W	1.7 W	1.0 W	40 mA	45 mA	33 mA	4.8 W	5.2 W	4.0 W
EM powerLED 2 W PRO EZ-3	2 h	0.55c	18 mA	21 mA	13 mA	1.6 W	2.1 W	1.0 W	40 mA	45 mA	33 mA	5.0 W	5.5 W	4.0 W
EM powerLED 2 W PRO EZ-3	3 h	0.55c	20 mA	24 mA	13 mA	1.9 W	2.5 W	1.0 W	40 mA	45 mA	33 mA	5.2 W	5.8 W	4.0 W

^① Maintained operation

[®] EM = Emergency

Test switch EM2

Product description

- For connection to the emergency lighting unit
- For checking the device function



Ordering data

Type	Article number	Packaging, bag	Packaging, carton	Weight per pc.
Test switch EM 2	89805277	25 pc(s).	600 pc(s).	0.011 kg

Status indication bi-colour LED

Product description

- Two-colour status display LED
- Green: system OK, red: fault



Ordering data

Type	Article number	Packaging, bag	Packaging, carton	Weight per pc.
LED EM bi-colour	89899720	25 pc(s).	200 pc(s).	0.017 kg
LED EM bi-colour, high brightness	89899753	25 pc(s).	800 pc(s).	0.013 kg

Battery selection

EM powerLED 1-2 W ST, 1 / 2 / 3 h

		Type	EM powerLED 1 W ST			EM powerLED 2 W ST		
		Article no.	89899860, 89899867			89899861, 89899868		
		Duration	1 h	2 h	3 h	1 h	2 h	3 h
		Cells	2 cells	3 cells	3 cells	3 cells	4 cells	5 cells
Technology and capacity	Design	Number of cells	Type	Article no.	Assignable batteries			
NiMH 2.2Ah Cs cells	stick	1 x 2	Accu-NiMH 2A	28002087	•			
	stick	1 x 3	Accu-NiMH 3A	28002088		•	•	•
	stick	1 x 4	Accu-NiMH 4A	28002089				•
	stick	1 x 5	Accu-NiMH 5A	28002090				•
	side by side	5 x 1	Accu-NiMH 5B	28002093				•

Battery charge / discharge data

EM powerLED 1-2 W ST, 1 / 2 / 3 h

		Type	EM powerLED 1 W ST			EM powerLED 2 W ST		
		Article no.	89899860, 89899867			89899861, 89899868		
		Duration	1 h	2 h	3 h	1 h	2 h	3 h
		Cells	2 cells	3 cells	3 cells	3 cells	4 cells	5 cells
Battery charge time	Initial charge	20 h						
	Fast recharge	12 h						
	Trickle charge	continuously (pulse charge)						
Charge current	Initial charge	130 mA						
	Fast recharge	210 mA						
	Trickle charge	130 mA / 0 mA (4 min. / 16 min.)						
Discharge current	1 x LED	770 mA	460 mA	460 mA	900 mA	640 mA	500 mA	
	2 x LED	–	–	–	870 mA	630 mA	500 mA	

LED current



EM powerLED 1-2 W ST, 1 / 2 / 3 h

		Type	EM powerLED 1 W ST			EM powerLED 2 W ST		
		Article no.	89899860, 89899867			89899861, 89899868		
LED current in emergency operation	1 x LED	350 mA			600 mA			
	2 x LED	–			350 mA			
LED current in mains operation	1 x LED	350 mA			350 mA			
	2 x LED	–			350 mA			

Standards

- according to EN 50172
- according to EN 60598-2-22
- EN 61347-2-7
- EN 61347-2-13
- EN 62384
- EN 62034
- EN 55015
- EN 61000-3-2
- EN 61547
- EN 60068-2-64
- EN 60068-2-29
- EN 60068-2-30

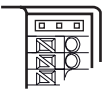
Duration link selection

Duration	Link Position
1 hr	 without jumper
2 hr	 position A
3 hr	 position B

Jumper selection

Module supplied with jumper in 3 hours position (position B).

The position of the link will only be read on first power up. If it is changed afterwards both the battery and mains supply must be disconnected for 10 seconds to enable the EM powerLED to read the new link position on reconnection of the battery and mains. It will lead to a false battery failure indication if the link is changed after installation without this reset.

Technical data Accu-NiMH

2.2 Ah

Battery voltage/cell	1.2 V
Cell type	Cs
Case temperature range to ensure 4 years design life	+5 °C to +55 °C
Max. short term temperature (reduced life-time)	70 °C
Max. number discharge cycles	4 cycles per year plus 30 cycles during commissioning
Max. storage time	6 months

Batteries

Connection method: 4.8 x 0.5 mm spade tag welded to end of cell

For stick packs this connection is accessible after the battery caps have been fitted.

To inhibit inverter operation disconnect the batteries by removing the connector from the battery spade tag.

For further information refer to corresponding battery datasheet.

Storage, installation and commissioning

Relevant information about storage conditions, installation and commissioning are provided in the battery datasheets.

Further technical data

The EM powerLED has a unique power regulation circuit; this is designed to limit the total power drawn from the battery in the event of using LED's with a forward voltage (Vf) higher than 3.4 V.

In such cases the unit will reduce the LED current in order to maintain an acceptable drain current from the battery and hence meet the required duration time. This feature enables the EM powerLED to have minimum battery count for a given range of LED's.

At a low charge state of the battery (<1.5V at the 1W driver and <3V at the 2W driver) the LED will not be driven in maintained mode via the switched line until the rated battery voltage levels are exceeded.

Testing

Functional test

Functional tests are carried out for 5 seconds on a weekly basis under the control of the Micro controller. Initiation and timing of these tests is set during the commissioning of the luminaire.

Duration test

A full duration test is carried out yearly to check the capacity of the batteries.

For a full description of commissioning and test features please refer to application notes.

Commissioning

After installation of the luminaire and initial connection of the mains supply and battery supply to the EM powerLED ST the unit will commence charging the batteries for 20 hours (initial charge). Afterwards the module will conduct a commissioning test for the full duration. The 20 hours recharge occurs also if a new battery is connected or the module exits the rest mode condition.

The following automatic commissioning duration test is only performed when a battery is replaced and fully charged (after 20 hours).

The easy commissioning feature will set the initial test day and time to ensure random testing of units.

Test switch

An optional test switch can be wired to each EM powerLED ST. This can be used to to:

- initiate a 5 seconds function test press 200 ms < T < 1 s
- execute function test as long as switch pressed > 1s press
- adjust local timing > 10 s press

Rest Mode / Inhibit Mode

Emergency operation is automatically started when the mains supply is switched off. If the Rest Mode is activated, the discharging of the battery will be minimized by switching off the LED output. If the Inhibit Mode has been activated before the mains supply is switched off, Rest Mode will be automatically activated if the mains supply is switched off within 15 minutes.

Rest Mode and Inhibit Mode can be initiated by applying a short pulse between 9,5 and 22,5 V_{DC} in amplitude for a period of 150 to 1,000 ms. This pulse shall be applied to terminals marked Rest.

After a mains reset the EM powerLED ST exits the Rest Mode. Rest Mode and Inhibit Mode can both be disabled by applying a voltage pulse of 1,000 to 2,000 ms to the terminals marked as Rest to send the RE-LIGHT/ RESET INHIBIT command.

Pulse/Mode	Standby	Emergency	Rest
150 – 1,000 ms	Inhibit	Rest	–
1,000 – 2,000 ms	Cancel inhibit	–	Re-light

Life-time

Average life-time 50,000 hours under rated conditions with a failure rate of less than 10 %. Average failure rate of 0.2% per 1000 operating hours.

Isolation and electric strength testing of luminaires

Electronic devices can be damaged by high voltage. This has to be considered during the routine testing of the luminaires in production.

According to IEC 60598-1 Annex Q (informative only!) or ENEC 303-Annex A, each luminaire should be submitted to an isolation test with 500 V_{DC} for 1 second. This test voltage should be connected between the inter-connected phase and neutral terminals and the earth terminal. The isolation resistance must be at least 2 M Ω .

As an alternative, IEC 60598-1 Annex Q describes a test of the electrical strength with 1,500 V_{AC} (or 1,414 x 1,500 V_{DC}). To avoid damage to the electronic devices this test must not be conducted.

Status indication

System status is indicated by a bi-colour LED.

LED Indication	Status	Commentary
Permanent green	System OK	AC mode
Fast flashing green (0.1s on – 0.1s off)	Function test underway	
Slow flashing green (1s on – 1s off)	Duration test underway	
Red LED on	Load failure	Open circuit / Short circuit / LED failure ^①
Slow flashing red (1s on – 1s off)	Battery failure	Battery failed the duration test or function / Battery is defect / Incorrect battery voltage
Fast flashing red (0.1s on – 0.1s off)	Charging failure	Incorrect charging current
Double pulsing green	Rest mode	Switching into blocking mode via controller
Green and red off	DC mode	Battery operation (Emergency mode)

① If the EM powerLED is operated in non-maintained mode and an LED fault is detected, the red indicator LED will be illuminated and the output will be stopped. The unswitched mains supply must be switched off before the LED is changed in order that the new LED can be detected. A function or duration test will not reset the fault indication.

Mechanical details

Case manufactured from polycarbonate.

Glow-wire test according to EN 61347-1 with increased temperature of 850 °C passed.

LED bi-colour status indicator

- Green / red
- Mounting hole 6.5 mm dia
- Lead length 1000 mm
- Insulation rating: 90 °C

Test switch

- Mounting hole 7.0 mm dia
- Lead length 550 mm

Battery leads

- Quantity: 1 red and 1 black
- Length: 1 m
- Wire type: 0.5 mm² solid conductor
- Insulation rating: 90 °C

Battery end termination

Push on 4.8 mm receptacle to suit battery spade fitted with insulating cover

Module end termination

8.0 mm stripped insulation

Two-piece batteries are supplied with a 200 mm lead with 4.8 mm receptacles at each end and insulating covers to connect the separate sticks together.

Recommended fixing details for clip fixing

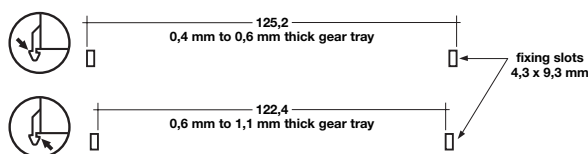

Max. torque at the clamping screw: 0.5 Nm / M4

Wiring type and cross section

Wiring

mains (SL, N, L)
LED (LED +, LED -)

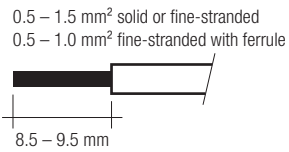

Wiring

batteries (Bat +, Bat -)
test switch (switch)
status indication LED (status K, A)

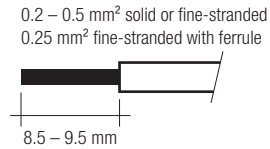

Use one wire for each terminal connector only.

Max. lead insulation diameter

Battery 2.1 mm
Test switch 2.1 mm
Indicator LED 2.1 mm

Maximum lead length

LED 3 m
status indication LED 1 m
batteries 1 m

Release of the wiring

Press down the “push button” and remove the cable from front.

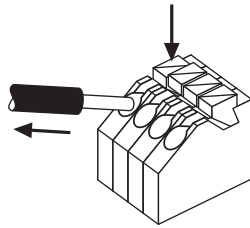

Maximum loading of automatic circuit breakers

Automatic circuit breaker type	B10	C10	B13	C13	B16	C16	B20	C20	Inrush current	
									I_{max}	time
Installation Ø	1.5 mm ²	1.5 mm ²	1.5 mm ²	1.5 mm ²	2.5 mm ²	2.5 mm ²	2.5 mm ²	2.5 mm ²		
EM powerLED 1 W ST	90	180	130	260	130	260	130	260	10 A	120 µs
EM powerLED 2 W ST	90	180	130	260	130	260	130	260	10 A	120 µs

Wiring diagram

Wiring diagram for one LED or two LED in series

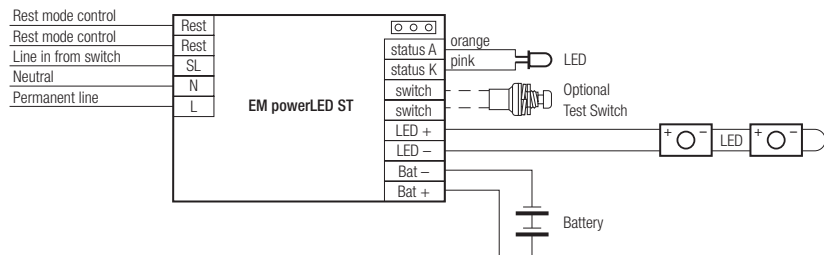

Wiring diagram for multiple LED (3–12) in parallel

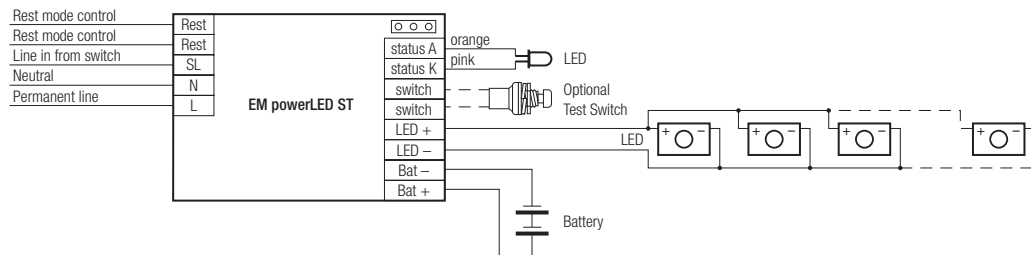

Take care that the LED is connected with the right polarity. LED that are connected to the EM powerLED devices should have a reverse polarity protection device such as a schottky diodes fitted, otherwise irreversible damage could occur if the LED is connected in reverse polarity. Any protection device must be capable of handling in excess of 700 mA.

Note: Please ensure that at the terminal of the EM powerLED module the battery negative is not connected to the negative of the LED load.

Manually tested emergency lighting with combined LED modules for general and emergency lighting (e.g. STARK QLE CLASSIC EM, STARK LLE 24-280-1250 EM, STARK CLE CLASSIC EM, STARK SLE CLASSIC EM):

Due to the fact that independent circuits are used for general and emergency lighting it is important that the normal supply of the mains LED Driver is switched off together with the permanent emergency supply prior to checking the operation of the emergency LEDs.

If this is not done then it may not be possible to see that the emergency LEDs are operating.

Use a circuit similar to that shown next.

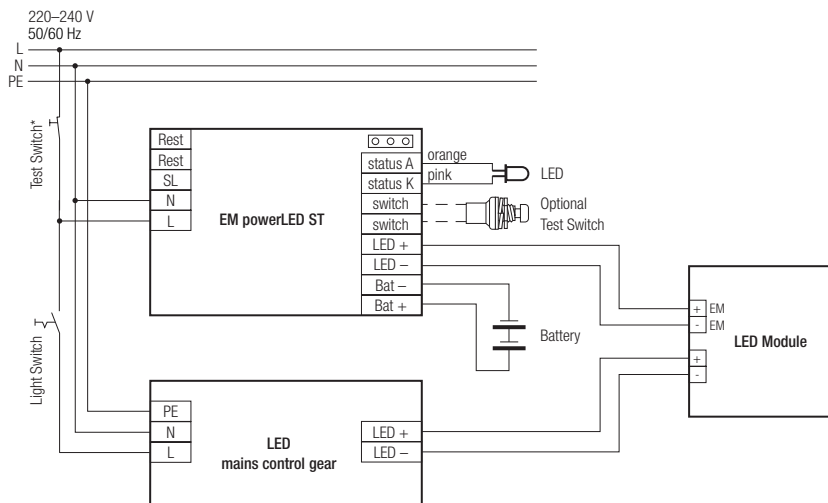

* Use 230 V Test switch

Simple CORRIDOR FUNCTION with EM powerLED 1-2 W

With the mains operation function of the EM powerLED 1-2 W a simple corridor function can be realised.

An external presence detector switches the mains LED Driver.

The EM powerLED 1-2 W has the switched line SL connected to permanent mains supply.

On presence both mains LED Driver and EM powerLED 1-2 W are active and driving all LEDs. With no presence the mains LED Driver is switched off by the presence detector and the EM powerLED 1-2 W stays on operating the emergency LEDs at low power.

Use a circuit similar to that shown next.

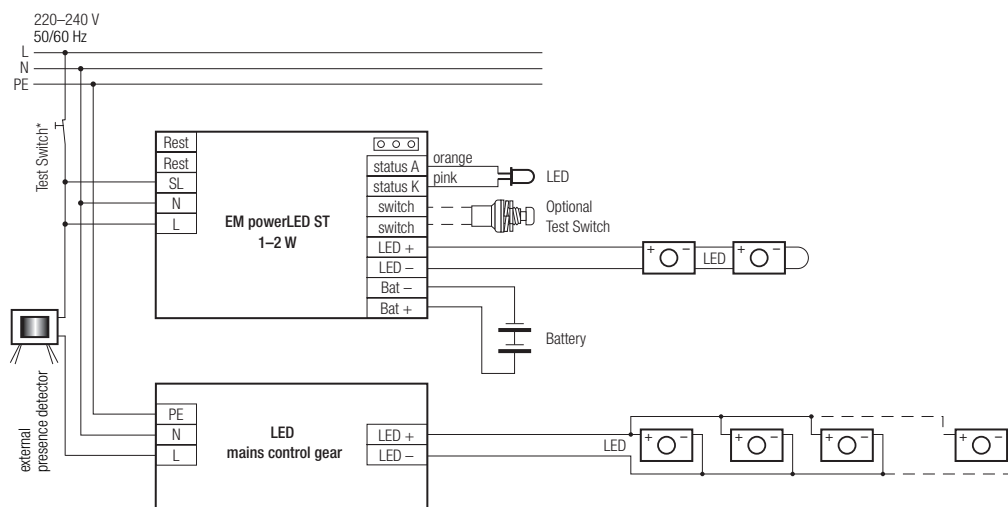

Wiring instructions

- The EM powerLED terminals, battery, indicator LED and test switch terminals are classified as SELV. Keep the wiring of the DALI and the input terminals separated from the wiring of the SELV terminals or consider special wiring (double insulation, 6 mm creepage and clearance) when these connections should be kept SELV.
- The output to the LED is DC but has high frequency content at 125 kHz, which should be considered for good EMC compliance.
- EM powerLED leads should be separated from the mains and DALI connections and wiring for good EMC performance.
- Maximum lead length on the EM powerLED terminals is 3 m. For a good EMC performance keep the LED wiring as short as possible.
- Maximum lead length for the test switch and Indicator LED connection is 1 m. The test switch and Indicator LED wiring should be separated from the EM powerLED leads to prevent noise coupling.
- Battery leads are specified with 0.5 mm² cross section and a length of < 1.3 m.
- DALI terminals are mains proof.
- Switched live and unswitched live supplies must be off the same phase.
- To avoid the damage of the control gear, the wiring must be protected against short circuits to earth (sharp edged metal parts, metal cable clips, louver, etc.).

Additional information

Additional technical information at www.tridonic.com → Technical Data

Guarantee conditions at www.tridonic.com → Services

Life-time declarations are informative and represent no warranty claim. No warranty if device was opened.